

HYDRAULIC EXCAVATOR

TB230

TAKEUCHI

From World First to World Leader



**DURANTE
RENTALS**

LOCAL. EQUIPMENT. RENTAL.



Product Features & Specifications

ENGINE

- U.S. EPA Final Tier 4
- Automatic Fuel Bleed System
- Dual Element Air Filter
- Automatic Idle

ELECTRICAL

- Multi-Informational Display
- Sealed Rocker Switches
- 12 volt System with 40 amp Alternator
- Halogen Work Lights: Two Forward Facing
- Engine Preheat
- Hour Meter
- Travel Alarm
- Horn

TAKEUCHI FLEET MANAGEMENT

- 2 Year Standard Service
- Minimize Downtime
- Remote Diagnostics
- Utilization Tracking
- Proactive Maintenance
- Control Costs

UNDERCARRIAGE AND FRAME

- Triple Flanged Track Rollers
- 2-Speed Travel with Automatic Shift
- Sloped Frame with Open Centers
- Heavy Duty Dozer Blade with Float
- Large Wrap Around Counterweight
- 11.8" Rubber Tracks
- Power Angle Blade with Float and, Bolt-on Cutting Edge (optional)

OPERATOR'S STATION

- ROPS / TOPS / OPG Four Post Canopy
- Deluxe High Back Suspension Seat
- Adjustable Arm Rests
- 2" Retractable Seat Belt
- 3" Retractable Seat Belt (optional)

HYDRAULIC & WORKING EQUIPMENT

- Variable Displacement, Open Center Hydraulics
- Cushioned Boom and Swing Cylinders
- Hydraulic Pilot Controls
- Proportional Auxiliary Controls with Detent
- Auxiliary Flow Adjustable from Operator's Seat
- Hydraulic Reservoir with Fluid Level Sight Gauge
- Primary Auxiliary Hydraulic Circuit Plumbed to Arm
- Multiple Attachment Presets
- Flow Selector Valve, Primary Auxiliary Circuit
- Pattern Change Valve (ISO or SAE)
- Pilot Accumulator
- Long Arm with Integrated Thumb Mount
- Main Boom Cylinder Guard
- Dual Pin Position Bucket (optional)
- Mechanical Bucket Quick Coupler (optional)
- Main Pin Hydraulic Thumb (optional)



Spacious Cabin



Automotive Styled Interior

TOUGH, POWERFUL, RELIABLE



2-Speed Travel w/ Auto Shift



Wraparound Counterweight



Triple Flanged Track Rollers

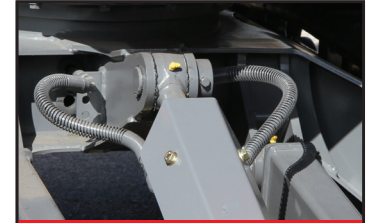

Segmented Lines

The TB230 is less than 5 ft 0.0 in wide giving it outstanding accessibility to job sites. It features all steel construction, a spacious operator station, automotive styled interior, smooth and powerful hydraulic system, pattern change valve, and cushioned boom and swing cylinders. The TB230 provides impressive dig depth, reach and lifting capacity for maximum productivity making it a great choice for the most demanding applications.

Additional features include a U.S. EPA Final Tier 4 compliant engine, automatic fuel bleed system, dual element air filter, and a large wraparound counterweight that protects engine components from damage. The operator is protected by a four post ROPS/TOPS/OPG operator protective structure that keeps the operator safe and comfortable on any job site.



Large lockable service hoods provide vandalism protection and outstanding maintenance access.

OPERATING PERFORMANCE

Operating Weight	6,360 lb	(2,885 kg)
Maximum Bucket Breakout Force	6,471 lb	(2,935 kg)
Maximum Arm Digging Force	2,900 lb	(1,325 kg)
Arm Length	4 ft 9.0 in	(1,445 mm)
Slew Speed	10.3 rpm	
Traction Force	6,340 lb	(2,876 kg)
Ground Pressure	4.3 psi	(29.4 kPa)
Max Travel Speed		
Low Range	1.8 mph	(2.9 km / hr)
High Range	3.2 mph	(5.2 km / hr)

HYDRAULIC SYSTEM

Total Hydraulic Flow	24.2 gpm	(91.6 Lpm)
Auxiliary Flow - Primary Circuit	13.4 gpm	(50.6 Lpm)
Hydraulic System Pressure	3,046 psi	(21.0 MPa)

ENGINE

Make / Model	Yanmar / 3TNV88F	
Displacement	81.0 cu in	(1.3 L)
Horsepower @ 2,400 rpm	24.4 hp	(18.2 kW)
Maximum Torque @ 1,440 rpm	63 ft-lb	(85.3 Nm)

FLUID CAPACITIES

Engine Lubrication	5.0 qt	(4.7 L)
Cooling System	4.2 qt	(4.0 L)
Fuel Tank Capacity	14.0 gal	(53.0 L)
Fuel Consumption (65% of Full Load)	0.8 gal / hr	(3.3 L / hr)
Hydraulic Reservoir Capacity	9.2 gal	(35.0 L)
Hydraulic System Capacity	14.8 gal	(56.0 L)



Multi-Informational Display



Work Lights





Long Arm with Thumb Mount



Main Boom Cylinder Guard

TB230 Lifting Capacities at Ground Level*

Lift Point Radius from Rotation Axis		9 ft (2,743 mm)		12 ft (3,657 mm)	
	Lifting Capacities Over Front, Blade Down	2,031 lb	(921 kg)	1,360 lb	(617 kg)
	Lifting Capacities Over Side	1,398 lb	(634 kg)	933 lb	(423 kg)

* Ratings based on ISO10567 and do not exceed 87% of hydraulic lift or 75% of tipping load.

ATTACHMENTS

Takeuchi now offers attachments for all of your Takeuchi equipment. See your authorized Takeuchi dealer for additional information and attachment options.

TB230 Compact Excavator

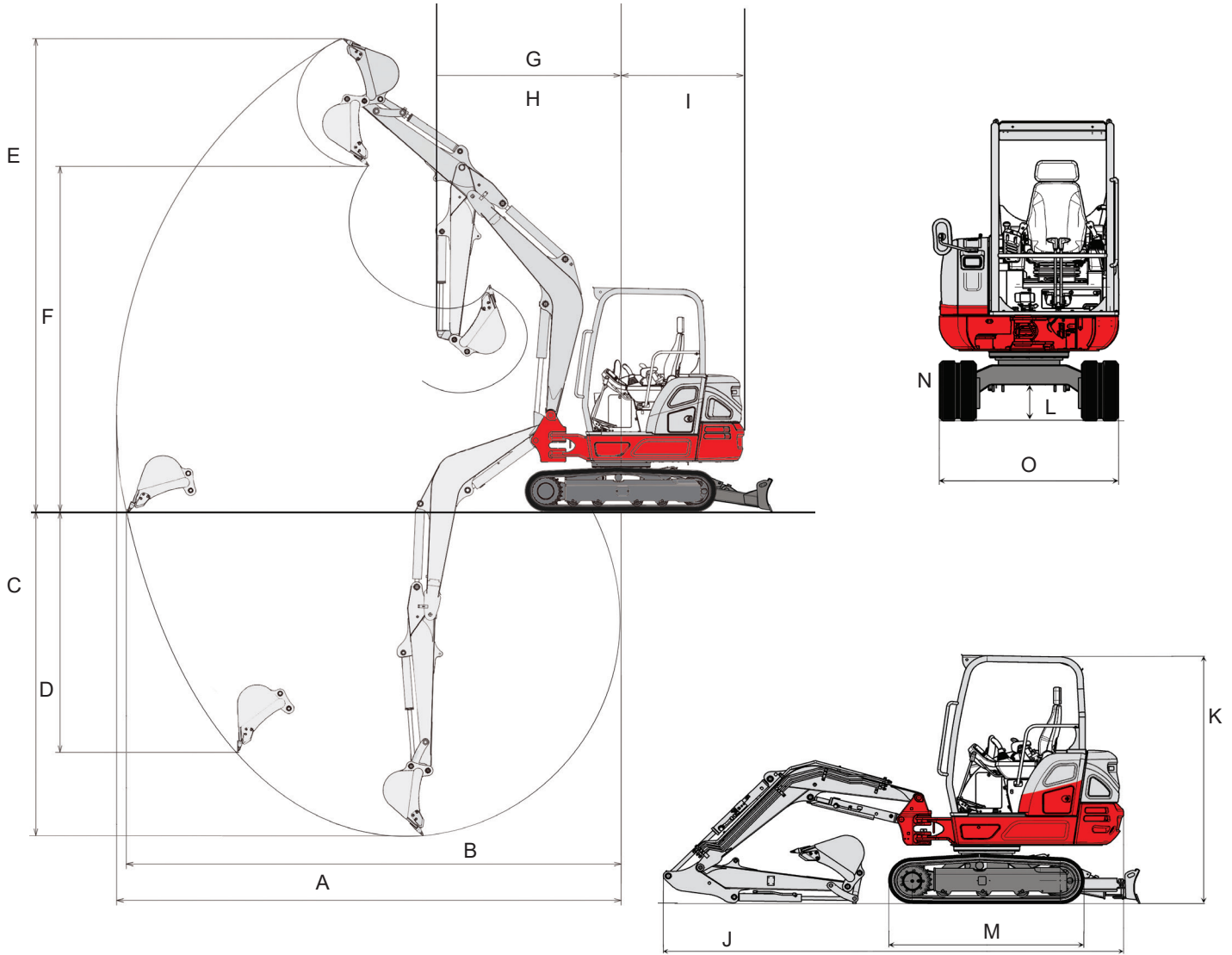

MACHINE DIMENSIONS

A	Maximum Reach	15 ft 10.9 in	(4,850 mm)
B	Maximum Reach at Ground Level	15 ft 5.4 in	(4,710 mm)
C	Maximum Digging Depth	9 ft 3.6 in	(2,835 mm)
D	Maximum Vertical Digging Depth	7 ft 1.2 in	(2,165 mm)
E	Maximum Dig Height	14 ft 7.0 in	(4,450 mm)
F	Maximum Dumping Height	10 ft 7.2 in	(3,230 mm)
G	Front Swing Radius	6 ft 2.7 in	(1,895 mm)
H	Front Swing Radius with Boom Offset	4 ft 11.2 in	(1,505 mm)
I	Tail Swing (Slew) Radius	4 ft 4.4 in	(1,330 mm)
J	Transport Length	15 ft 0.9 in	(4,595 mm)
K	Transport Height	8 ft 3.9 in	(2,540 mm)
L	Ground Clearance	11.9 in	(305 mm)
M	Undercarriage Length	6 ft 2.9 in	(1,900 mm)
N	Track Width (Rubber)	11.8 in	(300 mm)
O	Undercarriage Width	4 ft 9.1 in	(1,450 mm)



2 YEAR
2,000 HOUR
FULL MACHINE
WARRANTY



© 2020 Takeuchi Manufacturing (U.S.), Ltd. All Rights Reserved. Printed in the U.S.A.
In accordance with our established policy of continued improvement, specifications and features are subject to change without notice. Pictures may show options other than standard equipment.
FORM: TB230 Compact Excavator Spec Sheet - Jan. 2020 - (TFM) s/n 13000923 ~

Takeuchi
From World First to World Leader